

## SEMICONDUCTOR ELECTRONICS: MATERIALS, DEVICES AND SIMPLE CIRCUITS

### Class XII : PHYSICS WORKSHEET

---

1. How is a n-p-n transistor represented symbolically? (1)
2. How does conductivity of a semiconductor change with temperature? (1)
3. Draw energy band diagram for a p-type extrinsic semiconductor. (1)
4. Give the ratio of number of holes and the number of conduction electrons in an intrinsic semiconductor? (1)
5. What is the order of energy gap in the semiconductor? (1)
6. In the figure given below, state the type of biasing of the diode. (1)

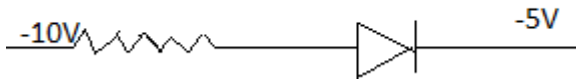

7. Which gate is represented by the symbol shown? (1)

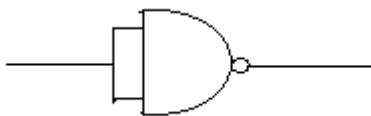

8. Frequency of input voltage to a half wave rectifier is 50 Hz. What will be the frequency of output voltage? (1)
9. What is potential barrier? How does the thickness of the depletion region in a p-n junction diode change, if it is forward biased? (2)
10. The output of an OR gate is connected to both the inputs of a NAND gate, draw the logic circuit of the combination of gates and write its truth table. (2)
11. What is a light emitting diode (LED)? Mention two important advantages of LEDs over conventional lamps (2)
12. For a transistor  $I_c/I_b = 0.96$ . Calculate the current gain in CE configuration. (2)

13. What is an ideal diode? Draw the output wave form across R for the input wave form given below. (2)

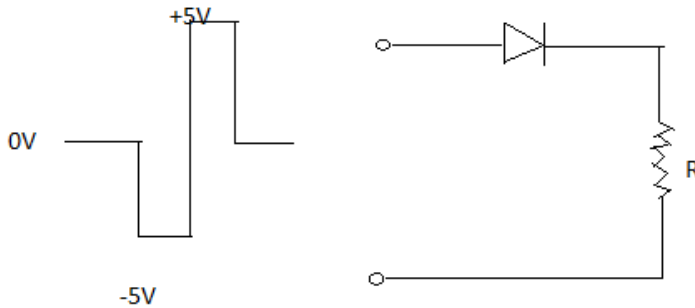

14. Draw the energy band diagram to distinguish between insulators, conductors and semiconductors. (2)

OR

With the help of a circuit diagram explain the use of Zener diode as voltage stabilizer.

15. The input resistance of a common emitter amplifier is  $2\text{ k}\Omega$  and a.c. current gain is 20. If the load resistor used  $5\text{ k}\Omega$ . Calculate (i) the voltage gain (ii) transconductance. (2)
16. Identify the logic gate marked, X, Y. Write down the output at y, when  $A=0, B=1$  AND  $A=1 B=0$ , (2)

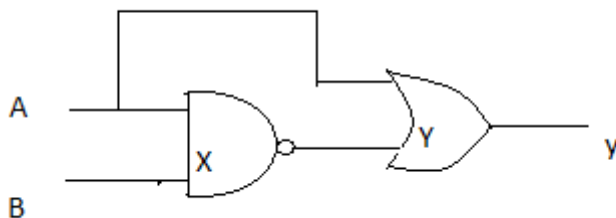

17. A photo diode is fabricated from a semiconductor with band gap of  $2.8\text{ eV}$ . Can it detect a wave length of  $6000\text{ nm}$ ? Justify. (2)
18. Draw a circuit diagram for a pn-junction diode in forward and reverse bias. Sketch the V-I graphs for them. (2)
19. Explain with neat diagram formation of energy bands in solids. Define conduction band and valance band. (3)
20. What is an intrinsic semiconductor? How can this material be converted in to p-type and n-type semiconductor? Explain with electron bond diagram. (3)

21. A transistor is used in common emitter mode in an amplifier circuit. When a signal of 24 mV is added to the base emitter voltage, the base current changes by  $32\mu\text{A}$  and collector current by 3.6 mA. The load resistance is 4.5 k $\Omega$ . Calculate (i) the current gain  $\beta$  (ii) the input resistance  $R_{be}$  (iii) the transconductance  $g_m$  (iv) the voltage gain  $A_v$ . (3)
22. Why NAND gate is called universal gate? Draw the diagram to convert NAND gate alone in to OR gate  
Or  
Using only NOR gate how to obtained (i) AND gate (ii) OR gate (3)
23. A semiconductor has an equal electron and hole concentration of  $6 \times 10^8 / \text{m}^3$ . On doping with certain impurity, electron concentration increases to  $4 \times 10^{10} / \text{m}^3$ . (3)
- What type of semiconductor is obtained on doping?
  - Calculate the new electron and hole concentration of the semiconductor.
  - How does the energy gap vary with doping?
24. What is the need of rectification? With the help of circuit diagram, explain the working of half wave rectifier. Draw its input and output wave forms. (3)
25. The ratio of the number density, of free electrons to holes,  $n_e / n_h$ , for three different materials A, B and C are equal to one, less than one more than one respectively. Name the type of semiconductor to which A, B and C belong. Draw labeled energy band diagrams for the three materials. (3)
26. Explain, with the help of a circuit diagram, how the thickness of depletion layer in a p-n junction diode changes when it is reverse biased. In the following circuits which one of the two diodes is forward biased and which is reverse biased? (3)

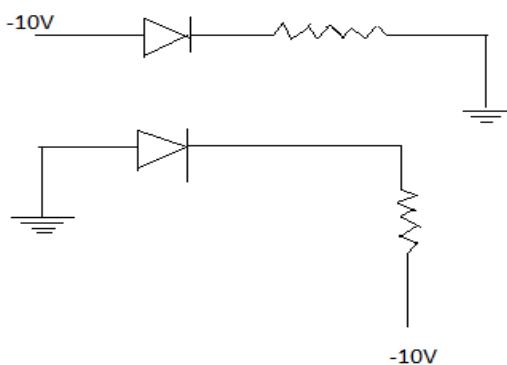

27. In the circuit shown below, a Zener diode of voltage  $V_Z$  ( $=6V$ ) is used to maintain a constant voltage across a load resistance ( $R_L$  ( $=1000\Omega$ )) by using a series resistance  $R$  ( $=100\Omega$ ). If the e.m.f of source ( $E$ ) is  $9V$ , calculate the value of current through series resistance, Zener diode and load resistance. What is the power being dissipated in Zener diode? (3)

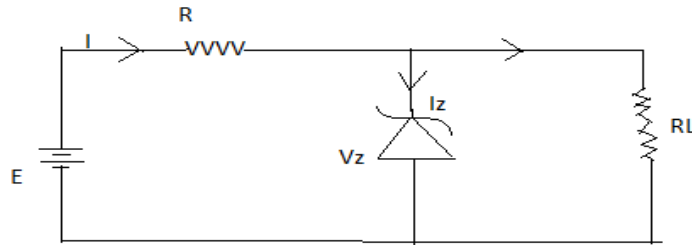

28. Explain through a labeled diagram, the working of a transistor as an amplifier (common-emitter configuration). Obtain an expression for the current gain, voltage gain and power gain.

OR

Draw a labeled circuit diagram of a transistor oscillator. Briefly explain its principle and state how the oscillations are sustained. (5)

29. State the principle of working of p-n diode as rectifier. Explain with the help of circuit diagram, the use of p-n diode as a full wave rectifier. Draw a sketch of the input and the output waveforms.

OR

Draw the circuit diagram to study the characteristic of npn transistor in common emitter configuration. Sketch typical (i) input characteristics (ii) output characteristics for such a configuration. Explain how the current gain of transistor is calculated from output characteristics. (5)

30. Draw the circuit diagram and transfer characteristics of a base biased transistor in common emitter configuration. Explain briefly the meaning of cut off, active and saturation region. Referring to the diagram explain transistor as a switch.

OR

State and define various basic gates. Draw the logic symbols and write the truth table for them. Explain how will you obtain NOR gate and NAND gate from them. For a binary signal 1101001, draw the wave form and output wave form for NOT gate.

\*\*\*\*\*

